

SECTION A - A

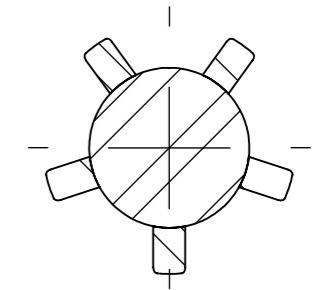

SECTION B - B

THE CAPSTAN BARS VARIED IN LENGTH. FOR ANCHOR RAISING, LONGER ONES WERE USED, ABOUT 10' - 12' LONG. WHEN UNDER WAY, SHORTER ONES, CALLED 'NORMANS', ABOUT 8' LONG, WERE USED.

THIS TYPE OF CAPSTAN, USED FROM THE 1780's HAD 10 CAPSTAN BARS AND 5 WHELPS. NOT ALL BARS SHOWN IN THESE DRAWINGS.

SIZES TAKEN FROM HMS PANDORA

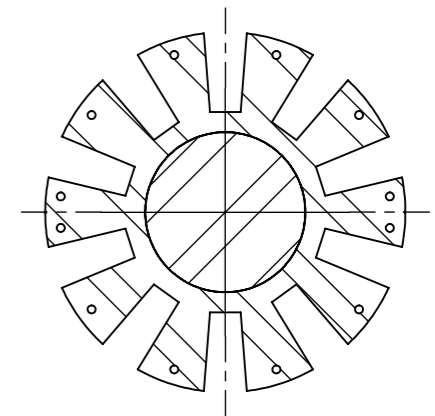

SECTION C - C

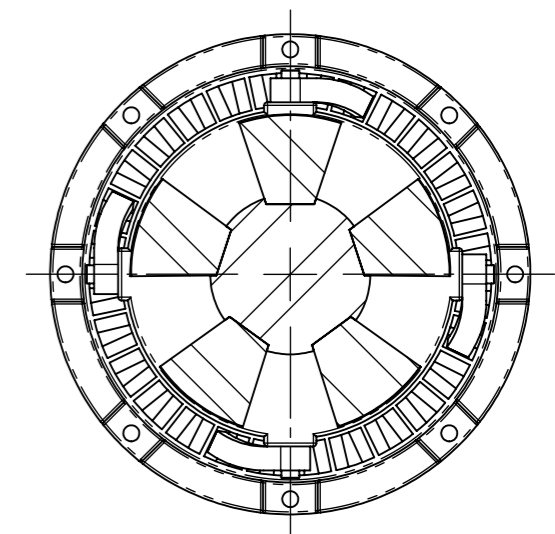

SECTION D - D

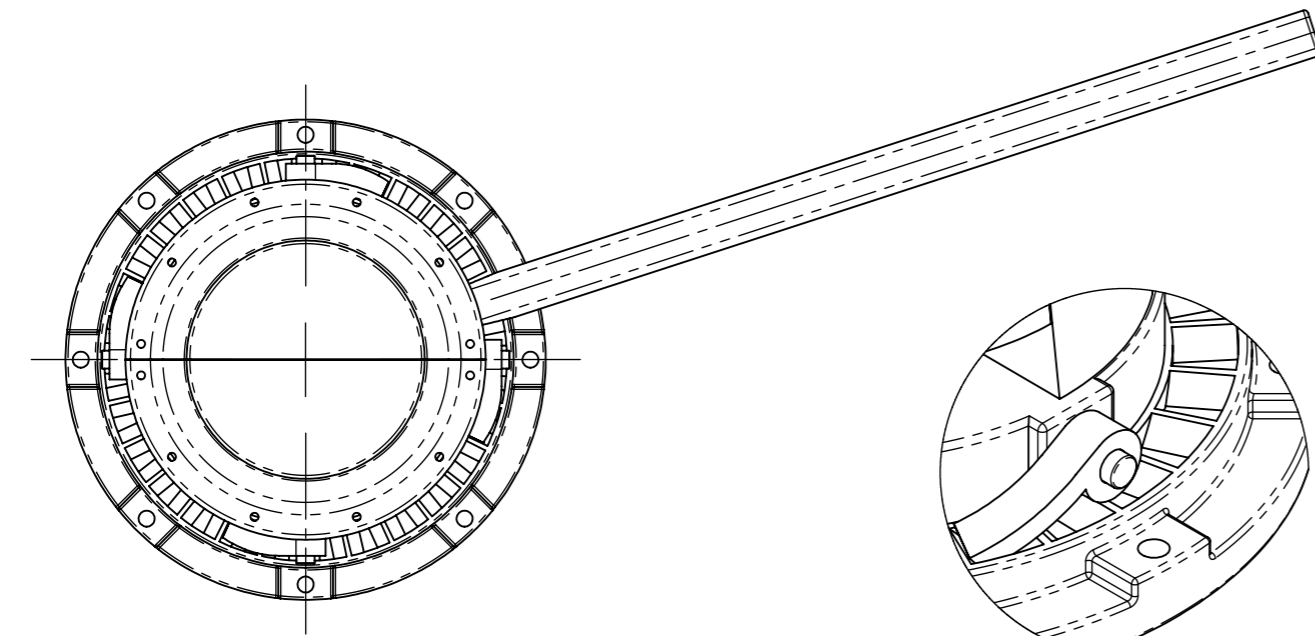

PLAN VIEW

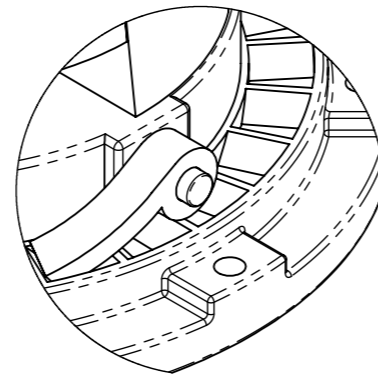

DETAIL F

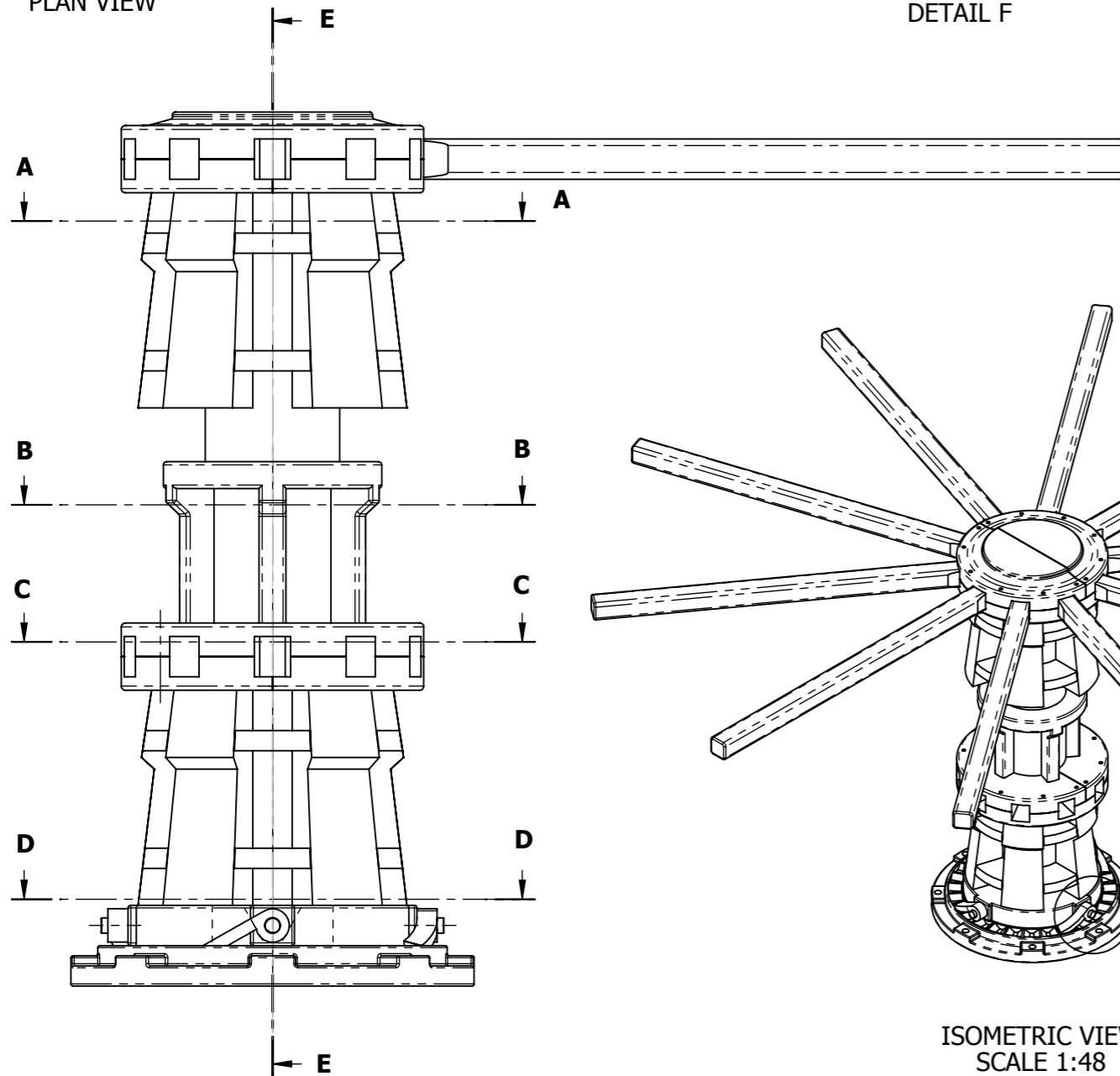

SIDE VIEW

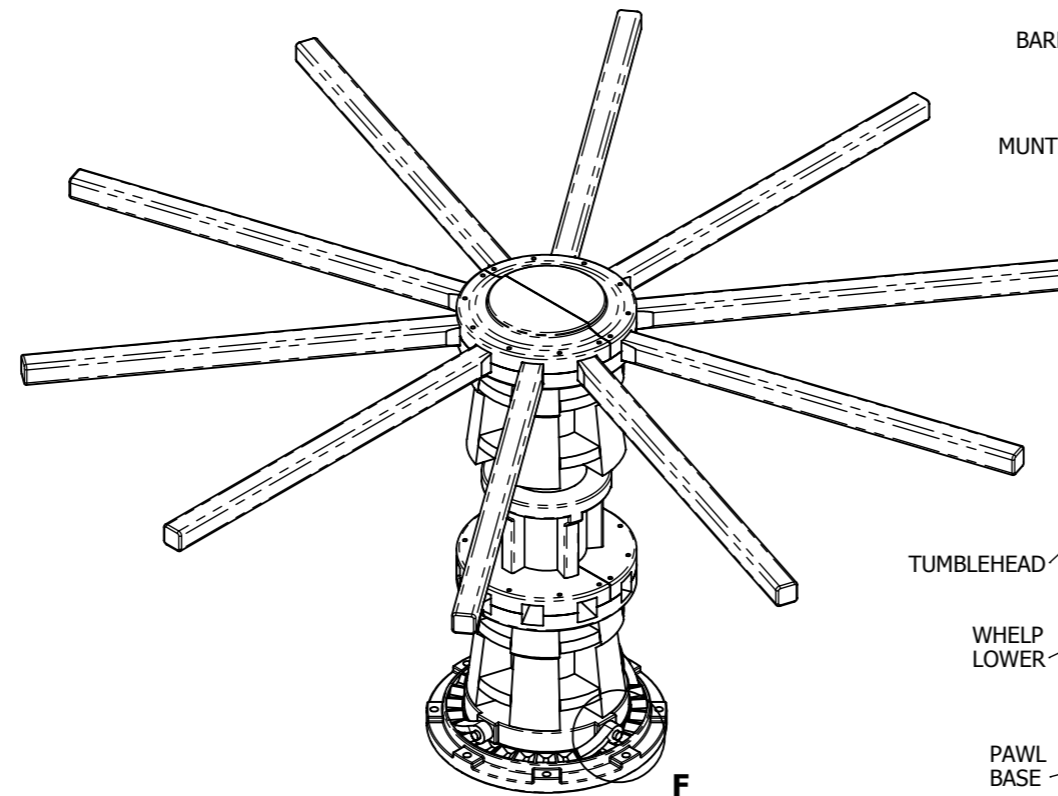

ISOMETRIC VIEW  
SCALE 1:48

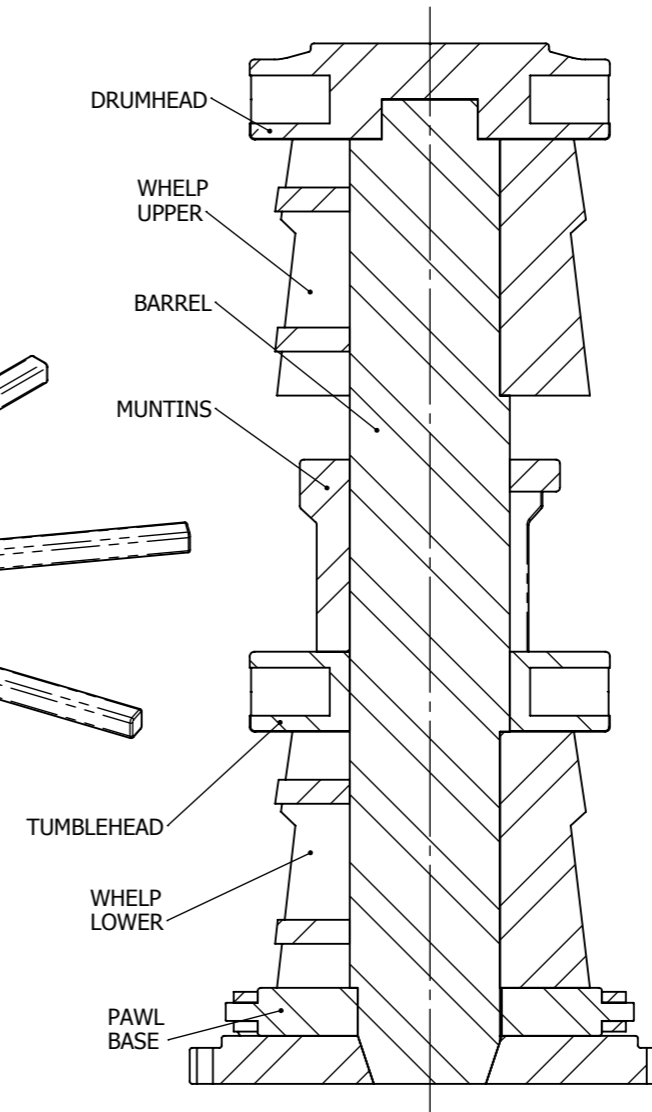

SECTION E - E

## DOUBLE CAPSTAN ARRANGEMENT

© COPYRIGHT MSW

SCALES : 1:24, 1:48

A3